

INSTALLATION AND USER MANUAL FOR THE AB-Q-ST70/ST120 AUTO BIAS MODULE

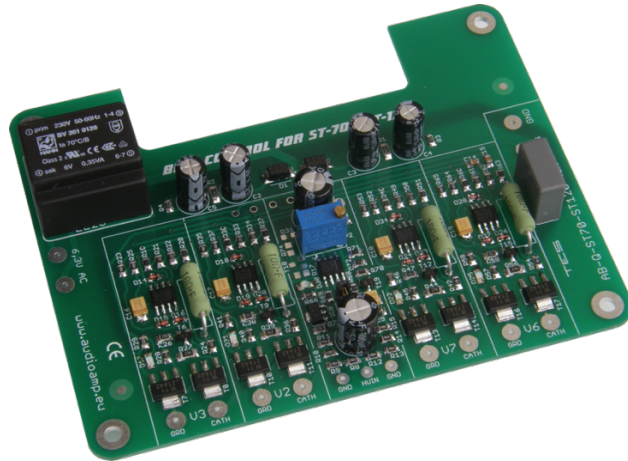

NOTE:

The new generation AB-Q-ST70/ST120 now comes with an onboard isolation transformer, which will ensure that no operational issues will arise from connecting the 6.3VAC filament supply to the auto bias module. Wiring of the 6.3VAC supply is the same as described in this manual, although some of the photos here show the module without this isolation transformer!

Introduction:

This module has been designed to maintain a constant bias voltage through all power output tubes for your ST70 or ST120 stereo power amp.

The bias is kept at a constant level on the output tubes, irrespective of the signal level.

Please note. The preset bias level for this AB-Q module, see below for details, will differ depending on whether your ST70 uses the KT88 or EL34 power tubes.

Benefits:

The advantage of using the AB-Q module is that it will extend output tube life, in a lot of cases it will also improve the sound and last but not least, you will never have to worry about adjusting the bias again.

- Instead of a pair of output tubes being biased together, now all four output tubes are individually biased for greater control and stability
- No need to keep an eye on and/or adjust the bias of the output tubes
- Significant extension of the output tubes life
- Bias is not influenced by the input signal
- Undistorted and improved sound for a great listening experience
- Reduction in hum and noise level of the amp
- No maintenance or additional adjustments are required after the initial setup
- Improved overall operation of the amp due to the reduction in the danger of a tube red plating
- The AB-Q ensures that bias is kept at the pre-set value (see Initial Setup) even as the tubes age
- The AB-Q comes with a soft start feature, which slowly brings up bias to each output tube
- negative DC bias supply between -60V to -120V

Quick Overview:

The AB-Q module has four **blue** LED's, one for each output tube, which when lit, indicate that bias is at the correct level and that all is good with each tube.

Should any of these **blue** LED's go out or not go on after power up, means that there is an issue with that given output tube and that the tube in question needs to be immediately replaced.

When the amp is powered up, at first a **red** LED will be on, indicating that there is power to the AB-Q module. The **red** LED will go out after about 20s.

After a further delay of between 40-50s, each of the **blue** LED's should come on indicating that the bias is now set and stable for each output tube. The amp is now ready to use.

IMPORTANT NOTES:

All the photo's used in this manual show the previous version of the AB-Q-ST70/ST120 module which did not have the isolation transformer on the pcb. Nothing has changed as far as the wiring and set up procedures are concerned between the early version and the current version you are now using!

We use 18gauge multi strand wire for all hookups. Try not to use solid core wire, it is a real pita and prone to break off at the solder joints.

Since the VTA pcb was designed many years before the AB module came on the market, there are no extra solder pads on the VTA pcb for the AB module wiring. So a lot of the hookup wires will need to share a pad on the VTA pcb where there is already a part in it. The best way is to trim the hookup wire quite short, pre tin it with solder, then solder it to the relevant VTA pcb pad. This works really and this is also the reason we recommend the use of 18gauge MULTI STRAND wire!

Preparing your ST70 or ST120 for the AB-Q module installation:

It is best that you remove the driver pcb, as this will make the preparation much easier for you.

You will also need to remove original 10 OHM cathode resistors, please refer to the following photos.

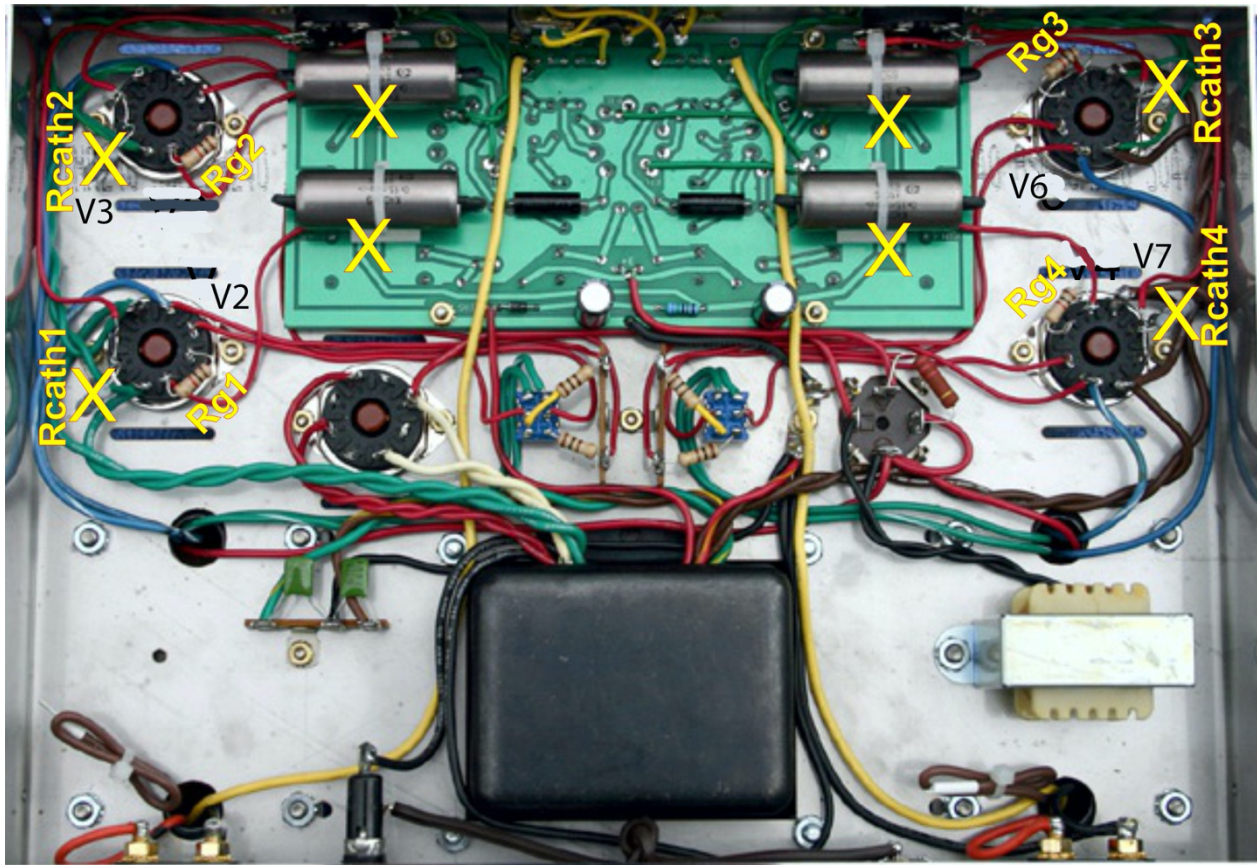

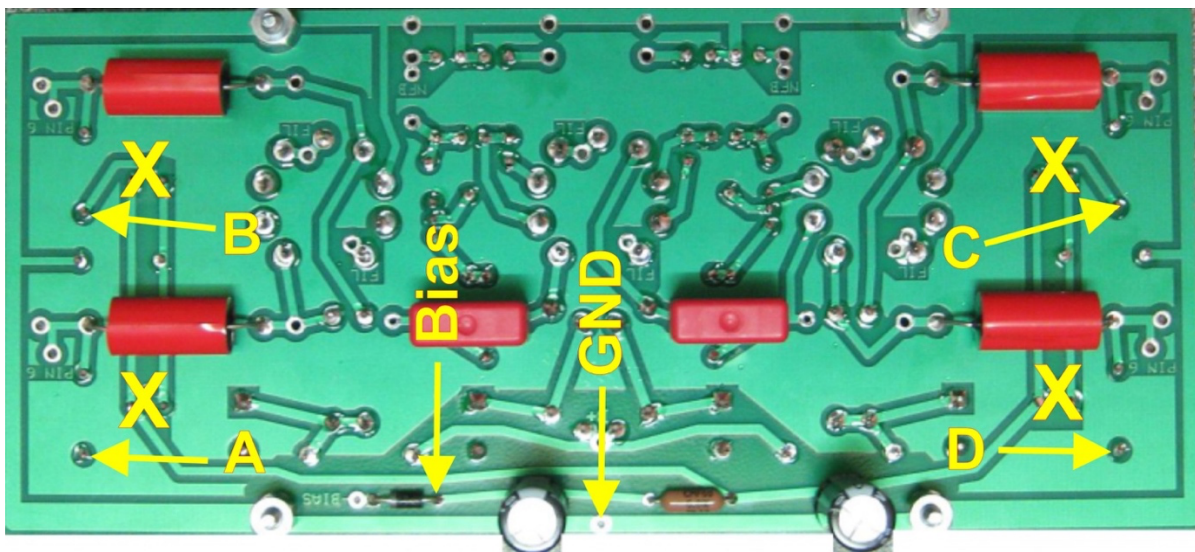
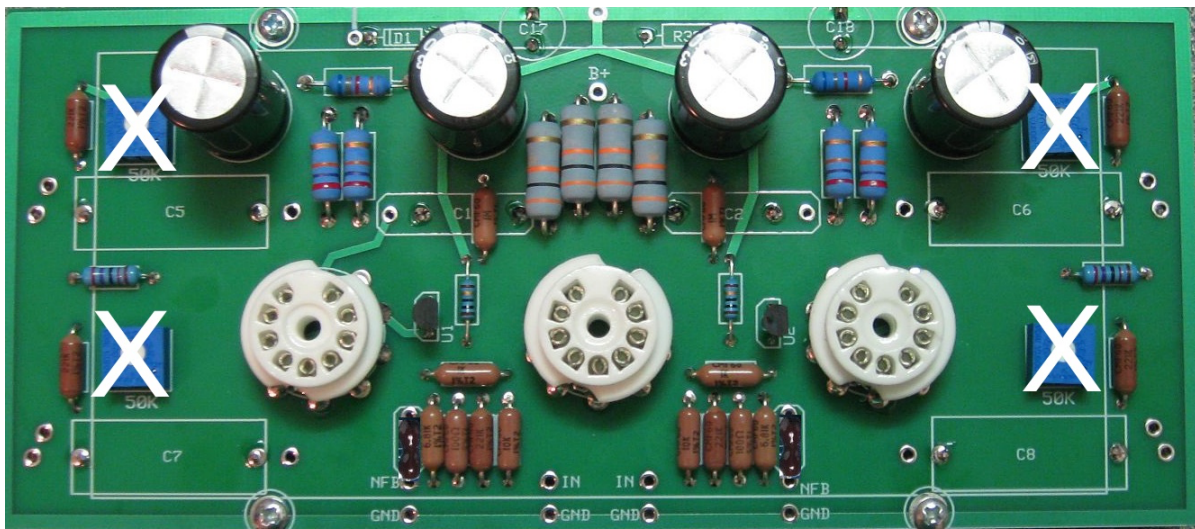

1. Remove the four 10 OHM bias resistors marked Rcath1 to Rcath4, connected to pins 1&8 on the four output tube sockets, marked with a **YELLOW X** on the photo
2. Remove the ST70/ST120 driver pcb
3. Remove the four original 50K bias trimmers from the ST70/120 driver pcb, marked with a **YELLOW X & WHITE X**
4. Solder one wire each, about 4" long, into the pcb pad indicated by the two **yellow arrows** marked **A, B, C & D**
5. Solder one wire to the **ANODE** end of the bias rectifier diode, marked **Bias** on the ST70/120 driver pcb,
6. Solder one wire to the **GND** pad marked **GND**, on the ST70/120 driver pcb
7. Do not re install the ST70/120 driver pcb yet!
8. Now refer to the 'Presetting your AB-Q-ST70-ST120 module bias level' section on the next page
9. **If your ST70 or ST120 has the time delay pcb fitted, this must be disconnected. You will need to remove the two red high voltage AC wires and connect them to pins 4 & 6 on the rectifier tube socket!**
You can leave the green/yellow and brown/yellow wires as well as the wire connected to the GND terminal to the timer module. Disconnect the two 6.3VAC wires from pins 2 & 7 from the V2 socket.

Presetting the AB-Q-ST70-ST120 module bias level:

Before the AB-Q module can be wired up, you need to preset its bias voltage.

For the ST70 or ST120 which KT88 power tubes, we recommend a bias level of 0.45V or 450mV.

For the ST70 with EL34 power tubes, we recommend a bias level of 0.40V or 400mV.

This bias level is set using the blue colored trimmer on the AB-Q module.

We strongly recommend that you preset the AB-Q module before you proceed with any of the wiring as well as before installing the AB-Q module in your ST70 or ST120!

We need to connect a 6.3VAC supply to the AB-Q module for the bias preset. If you have a spare transformer with a 6.3V winding, use that, if not, you will need to 'borrow' 6.3VAC from your ST70 or ST120.

If you have a spare transformer, wire it up and connect the 6.3VAC winding to the two **6,3 AC pads** on the AB-Q module.

If you need to 'borrow' your ST70/ST120, remove ALL tubes, including the rectifier tube. All we want is the 6.3VAC from the amp, we do not want any B+ high voltage DC!

BE CAREFUL, even though all tubes are removed, there will still be high voltage AC present at the rectifier tube socket!

Solder one wire each, on pin 2 and pin 7 to any power tube socket, V1 to V4, and connect the other end of each wire to the **6,3 AC pads** on your AB-Q module.

Place your AB-Q module on a non-conductive surface. Now switch on your ST70/ST120, or connect the spare transformer, and you should see the **red LED** on the AB-Q module light up. This LED will go out after about 20s.

Set your meter to read DC and to the lowest scale, say 1V, 2V or 5V. Put the black meter lead on any **GND** pad on the AB-Q module and put the red meter lead on the pad next to electrolytic capacitor, see below. Now adjust the blue trimmer until the desired bias level is achieved, see above for the different recommended bias levels.

That's it, you just set the AB-Q module to the desired bias operating level.

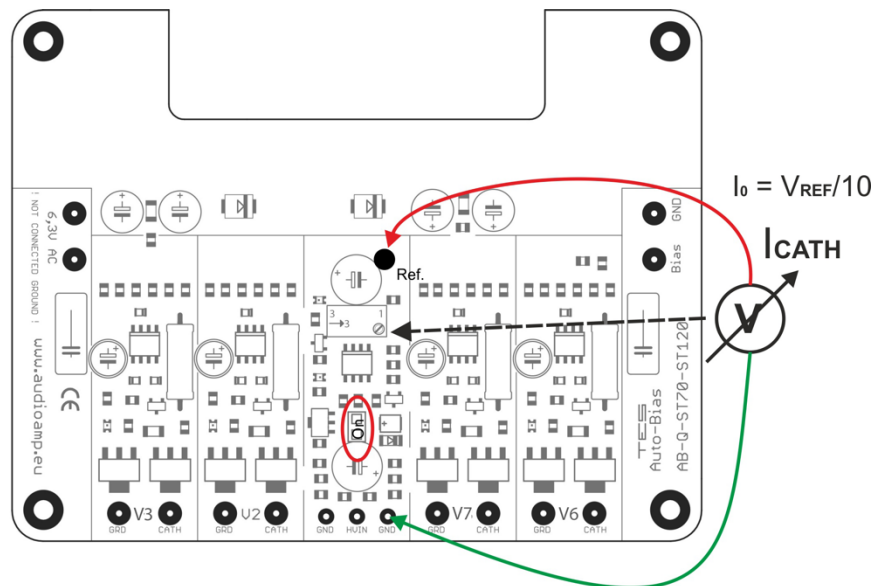

Disconnect the spare transformer or power down your ST70/ST120, wait for half a minute or so and disconnect the wires from the 6,3 AC pads on the AB-Q module.

We DO NOT recommend that you re adjust the bias level once module is installed. It can however, be done. After startup and amp running, measure at the tubes cathode in mV and adjust the AB modules trimmer to the desired bias level.

NOTE: the above AB-Q-ST70/ST120 drawing does not show the isolation transformer fitted to the pcb, however setting the bias level is the same!

Installing and wiring the AB-Q module into your ST70/ST120:

You will need to solder all the connecting wires to the AB-Q module. For ease of installation, solder all the wires on the top side of the AB-Q module. Make each of these wires about 7" long.

1. Solder a 7" long wire to each of the following AB-Q module solder pads: V2 CATH, V3CATH, V6 CATH, V7 CATH and the two pads marked 6,3 AC.
2. DO NOT connect any wires to pads BIAS, GND, V2 GRD, V3 GRD, V6 GRD and V7 GRD as yet, this is done below!
3. The wires in the two 6,3 AC pads should now be tightly twisted, as these are the 6.3VAC supply wires for the AB-Q module and being AC, have to be twisted to ensure hum free operation!

Before re installing the driver pcb and the AB-Q module, you need to connect the six 4" wires previously soldered to the ST70/120 driver pcb.

This procedure can be a bit of a handful in trying to keep all the pre-soldered wires in check, but do the best you can ☺

Trim each wire to the desired length.

4. Connect the wire marked by the **yellow arrow A** on the ST70/120 driver pcb, to the **V2 GRD** pad on the AB-Q module, shown as a violet wire in the below wiring diagram
5. Connect the wire marked by the **yellow arrow B** on the ST70/120 driver pcb, to the **V3 GRD** pad on the AB-Q module, also shown as a violet wire in the below wiring diagram
6. Connect the wire marked by the **yellow arrow C** on the ST70/120 driver pcb, to the **V6 GRD** pad on the AB-Q module, also shown as a violet wire in the below wiring diagram
7. Connect the wire marked by the **yellow arrow D** on the ST70/120 driver pcb, to the **V7 GRD** pad on the AB-Q module, also shown as a violet wire in the below wiring diagram
8. Connect the wire from the **ANODE** end of the bias supply diode marked by the **yellow arrow Bias** on the ST70/120 driver pcb, to the **Bias** pad on the AB-Q module
9. Connect the wire marked by the **yellow arrow GND** on the ST70/120 driver pcb to the **GND** pad on the AB-Q module
10. Connect the two twisted wires from the two 6,3 AC pads on the AB-Q module to pins **2 & 7** respectively on the power tube socket for **V3**, also shown as the two yellow wires in the below wiring diagram. Route these AC wires neatly along the chassis wall and away from any DC or signal wires.

Use ½" long spacers, we recommend threaded 4-40 aluminum spacers, to now re installed your ST-70/ST-120 driver pcb as well as the AB-Q module. The holes in the AB-Q modules are arranged so that the module pcb will fit in the same mounting holes as those used for the driver pcb, see photo two pages down.

Once the AB-Q module is installed, you can start wiring to the tubes.

11. Re-connect the Rg1 wire from the VTA driver board to **pin 6** in the **V2** socket
12. Re-connect the Rg2 wire from the VTA driver board to **pin 6** in the **V3** socket
13. Re-connect the Rg3 wire from the VTA driver board to **pin 6** in the **V6** socket
14. Re-connect the Rg4 wire from the VTA driver board to **pin 6** in the **V7** socket
15. Connect the wire from the V3 CATH pad on the AB-Q module to **pin 1&8** in the **V3** socket, also shown as a red wire in the below wiring diagram
16. Connect the wire from the V2 CATH pad on the AB-Q module to **pin 1&8** in the **V2** socket, also shown as a red wire in the below wiring diagram
17. Connect the wire from the V7 CATH pad on the AB-Q module to **pin 1&8** in the **V7** socket, also shown as a red wire in the below wiring diagram
18. Connect the wire from the V6 CATH pad on the AB-Q module to **pin 1&8** in the **V6** socket, also shown as a red wire in the below wiring diagram

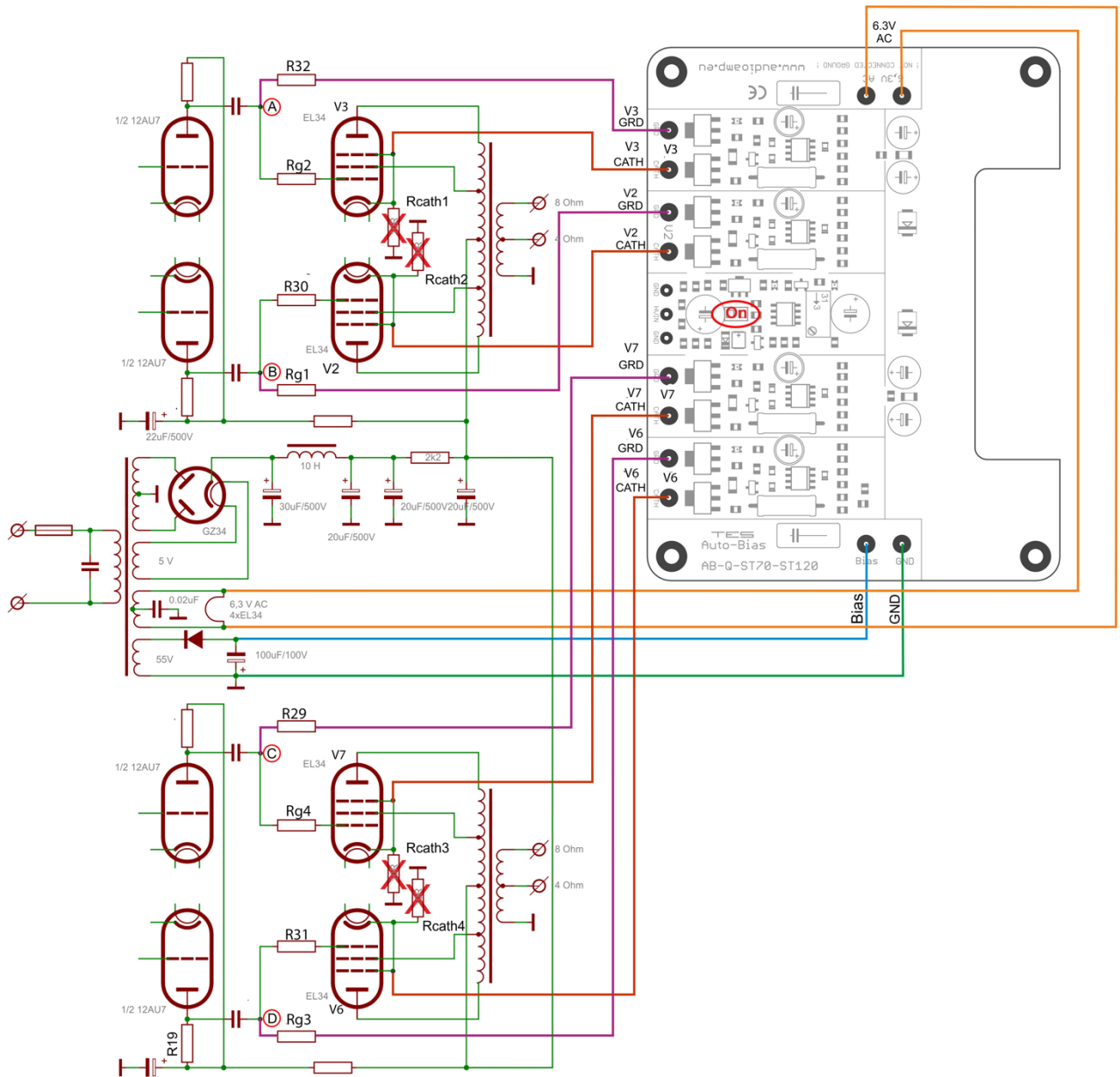

Use this diagram as a reference to the wiring of the AB-Q module as detailed in the above steps.

NOTE: the above AB-Q-ST70/ST120 drawing does not show the isolation transformer fitted to the pcb, however the 6.3VAC connection is the same!

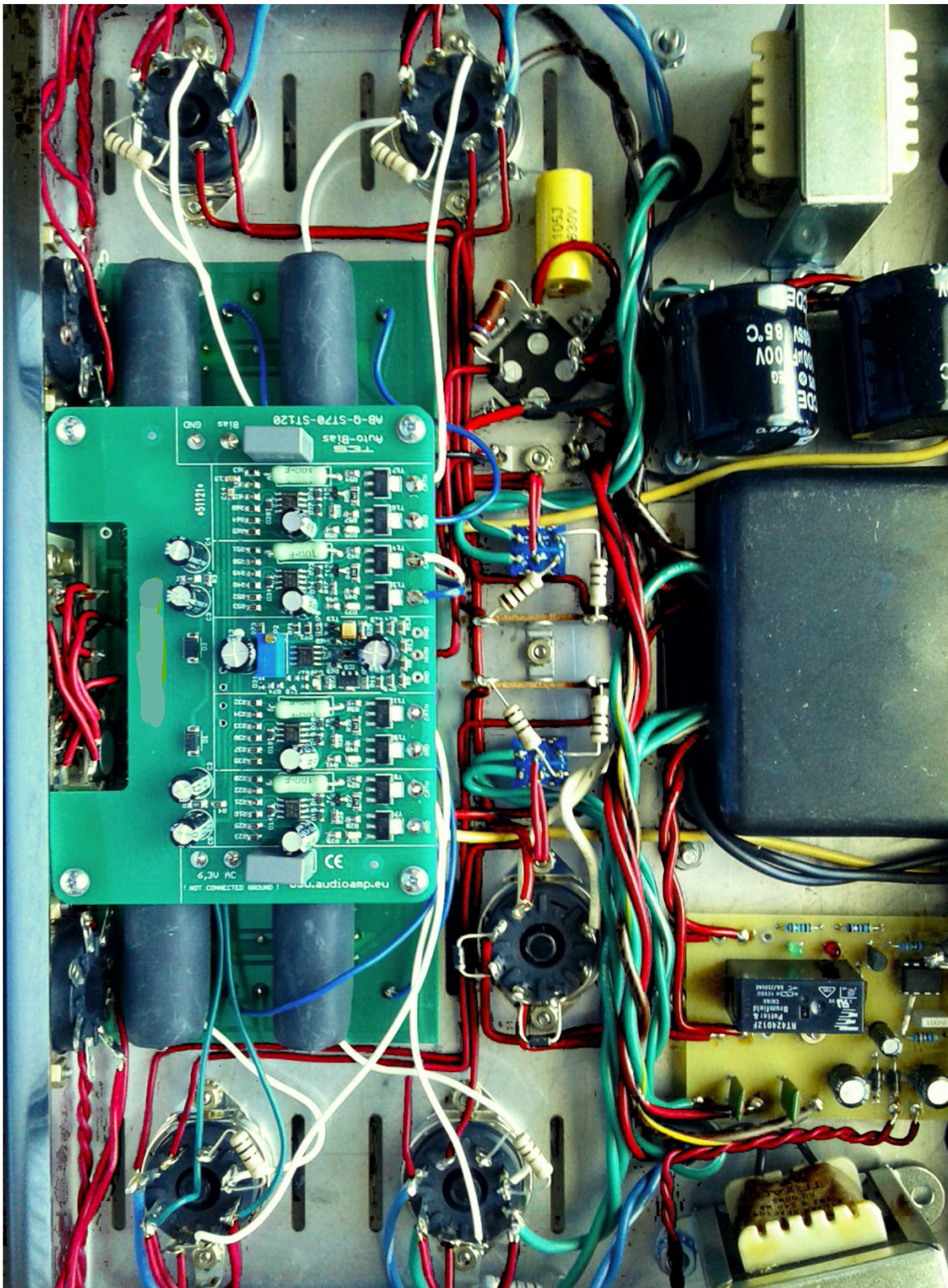

This shows the AB-Q-ST70-ST120 module installed above the ST70/ST120 driver pcb using the supplied spacers and screws and wired up. Keep all of the above wires neat and tidy, maybe use zip ties to group them.

This now pretty much completes the wiring of the AB-Q module to the ST70/ST120 driver pcb and the power tubes.

Double check all the wiring steps again, even triple check them ☺

Once you are confident that all your wiring is correct and as per the above steps, it is time to test your AB-Q module installation. We are assuming that you have installed the AB-Q module into a known working ST70/ST120, not a brand new ST70/ST120 kit build, as you would need to carry out a different sequence of testing your ST70/ST120 before you should power up the AB-Q module.

Plug in all tubes, that is the driver tubes, power tubes and the tube rectifier. In order to see the blue LED's on the AB-Q module, put your ST70/ST120 on its side.

Maybe stick a piece of styrofoam under one of the output transformers to cradle the ST70/ST120 chassis so that the tubes do not touch the bench top.

Connect an 8 OHM dummy load of at least 100W capacity or your speaker and if you can, short the input using a dummy RCA plug.

Power up your amp. The red LED on the AB-Q module should come on straight away and will go out after about 20s.

After an additional 40 to 50s, each of the blue LED's on the AB-Q module should start to come on, which indicates that each output tube has reached the preset bias level and all is good. Excellent!

You can measure the actual bias voltage on each output tube with a meter just to double check.

Set your volt meter to the 1V, 2V or 5V scale in DC volts. Put the red meter lead on pin 1/8 on a power tube socket, V1 to V4 and place the black meter to the chassis star ground tag. The meter should read close to 0.450V/450mV if KT88's are used or 0.40V/400mV if EL34's are used. This reading might be a little higher to start with and will get close to or exactly to the preset bias voltage as the output tubes warm up.

Do this measurement for each output tube, V1 to V4, measuring at pins 1/8.

Leave the amp running for about 10 minutes, all four of the blue LED's should remain lit.

Power down the amp and let everything cool down a bit then put the bottom chassis cover back on.

Remove the dummy RCA plug.

Place your ST70/ST120 amp in its spot, connect your speakers, RCA input and power lead to it and power the amp back up. After about a minute or so, the amps are ready for your listening session!

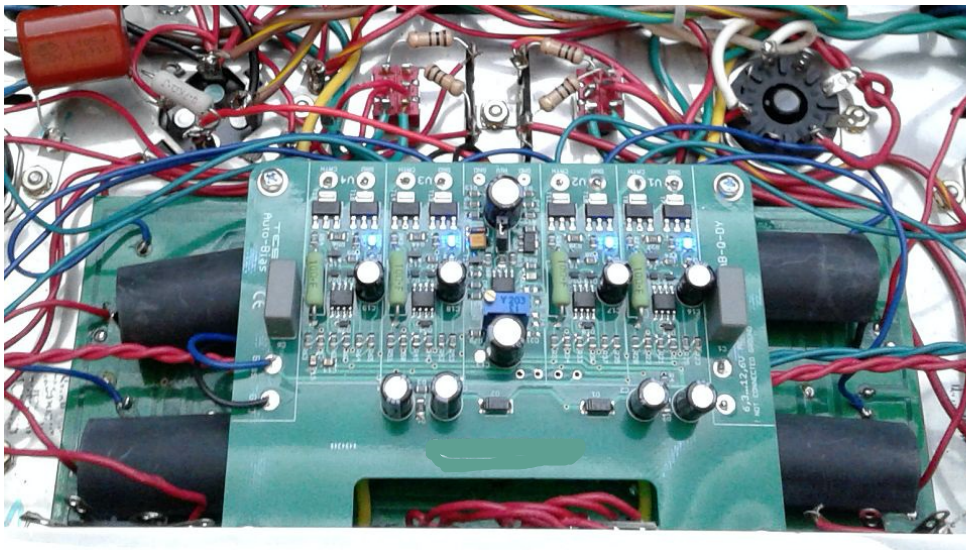

If things do not work as they are supposed to:

If the red LED on the AB-Q module does not come on immediately after the amp is powered up, power it back down and check the wiring/connections from pins 2 & 7 on the V2 socket to the two 6,3 AC pads on the AB-Q module. Make sure all is good there!

If none of the blue LED's come on after the 40-50s soft start delay, power the amp back down. Check all your wiring from the AB-Q module to each of the output tube pins and to the ST70/ST120 driver pcb.

If say only three or two of the blue LED's come on after the soft start delay, power the amp back down and check the wiring to that particular tube for which the blue LED did not go on for. Also check to make sure that the pins in that tube socket are nice and tight and that the tube fits into the socket not at all loose.

Also check the pins in the tube socket of any oxidization, if they are dirty, perhaps use Deoxit or similar to clean the pins!

Do's and don'ts:

Do check that the pins in each tube socket are tight and that each tube does not fit loosely in the socket. Do check that the pins in each tube socket are clean of oxidization, use Deoxit or similar if they are not clean.

Good fitting and clean pins in tube sockets make ALL the difference!!

Don't do a lot of tube rolling! This is a sure way to loosen up the pins in your sockets! If you cannot help yourself and you must do tube rolling, check the tightness of the pins each time you swap tubes!

Optional REMOTE LED installation:

The AB-Q circuit is designed as a general purpose auto bias module to suit just about any tube based amplifier.

Only the shape of the AB-Q-ST70/ST120 pcb has been changed in order to fit the ST70/ST120 chassis. The blue BIAS OK status LED's are surface mounted on to the AB module pcb, this reflects the 'general purpose' design philosophy of the AB module.

This however means, that once the chassis bottom cover has been re installed, these blue BIAS status LED's are no longer visible.

To make it easier to keep an eye on those status LED's, you can modify the AB module to have 'remote' status LED's. You can use either 3mm or 5mm standard LED's for this, any color will work.

For the ST70/ST120, remote LED's can be installed in place of the front octal sockets, you'll have to make up some kind of plate or similar, or some have drilled holes in the VTA driver pcb where the original bias trimmers were located, however, do this at your own risk!!

In order to do this, you must first remove the surface mount LED's from the AB module. This can be done using a soldering iron and some solder. Heat up the SMD LED by adding a small amount of solder to it, which will then loosen it off the pcb and it can be discarded.

Here is a good YouTube video of this process,

https://www.google.com/search?client=safari&rls=en&q=removing+SMD+components&ie=UTF-8&oe=UTF-8#kpvalbx=_52ZyXYbqHq--0PEPqCVgAc22

Once all the SMD LED's have been removed, use solder wick or a vacuum de soldering iron to remove the excess solder and you will expose the 'through hole' on each LED solder pad. This has been added so that 24gauge wire can be inserted for the remote LED.

Once you have decided on the location of the remote LED's, you will need to run a pair of wires for each LED from the AB module to the LED. We recommend that you use 24gauge pre twisted multistrand wire, the type we use is available from Jameco, here is the link,

<https://www.jameco.com/webapp/wcs/stores/servlet/ProductDisplay?catalogId=10001&freeText=173164&langId=-1&storeId=10001&productId=173164&krypto=N9Vn1io5hW0V02LRc8lYv%2BV0PM1tSsYv9Th8N3uFKNmcMLMULQy%2Fg0BH5Tq5GOWuTKq17TyOVIIlgxML6rNULbGjbktdmVg6tqwEbIh24g1%3D&ddkey=https%3AStoreCatalogDrillDownView>

You MUST be very careful with regards to the polarity of a LED. A LED as a Cathode/-ve and Anode/+ve end. This polarity MUST be maintained for the remote LED as well, see image next page which shows which AB module pcb pad is the Cathode/-ve and which is the Anode/+ve.

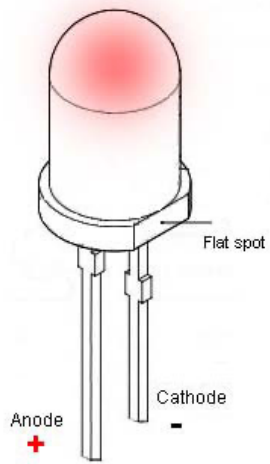

- The terminals of the LED can be identified as follows
- a) The shorter terminal is the Cathode/-ve
 - b) The flat spot also indicates the Cathode/-ve end

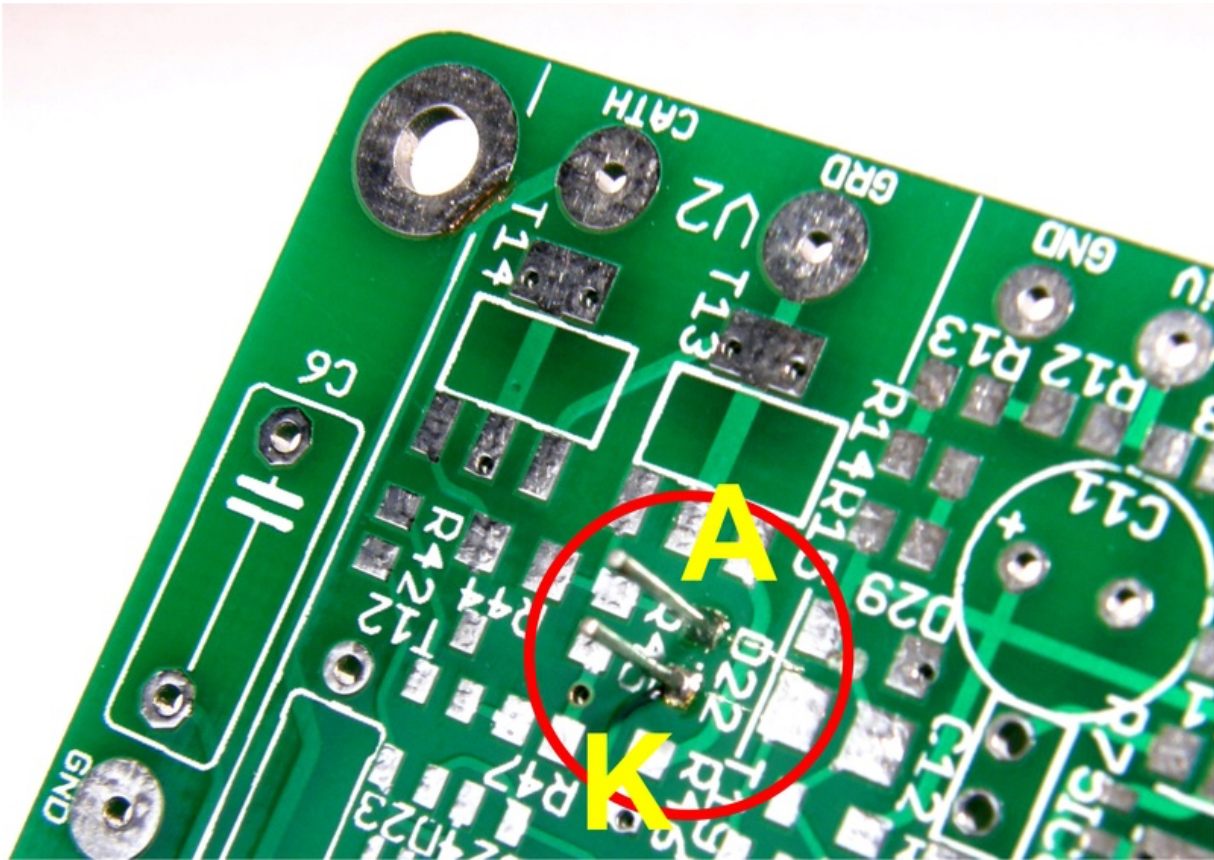

A = ANODE and K = Cathode

Following is a photo with remote 3mm green LED's fitted to an AB module pcb using the above mentioned 24gauge pre twisted wire. Here, the LED wires are wired in from the bottom of the AB module, but they can of course be mounted from the component side as well!
This photo will give you some idea anyway.

